



RONAIR Pet Food Dryer

Efficient drying system for aluminium pet food containers

Business challenge

Thanks to the combination of the advantages of air knife and Y slot plate technology, the industrial drying solutions of Ronair are particularly suited for drying of food packaging.

For this application, we have designed and built the Pet Food Dryer. The unique imbedded belt conveying system guides the product along the applied dryer elements. Thus, all sides of the product can be dried effectively in only one passage.



Our customer C&D Foods is a large producer of pet food that was looking for a cost and energy efficient solution to remove the water drops on the packaging of their products (aluminium containers of 100 and 150g).

Solution to several problems

The Ronair drying unit offers a solution to various problems that may occur during the packaging process. Some examples:

- The negative influence of water drops on camera inspection systems
- Unreadable or messy inkjet coding due to moisture
- Deviations of weight measurements
- Issues with condensation and mold
- Difficulties in the application of labels or sleeves on wet products



Test results

After performing various drying tests in our specialized lab, we can conclude that more than 99% of the water is removed by the Ronair Pet Food Dryer.



Benefits:

- Low-noise design
- Easy to maintain
- Quickly adjustable
- Easy integration in existing production lines
- Adaptable to your specific needs and requirements
- Energy efficient

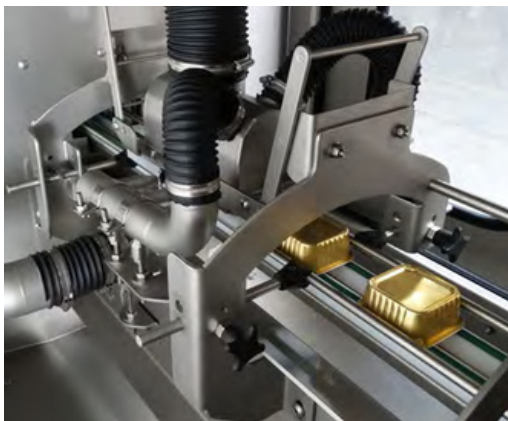

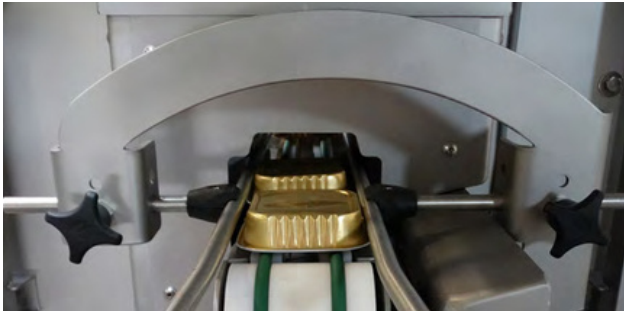

Technical specifications

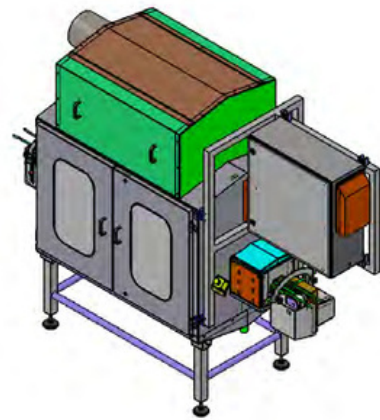
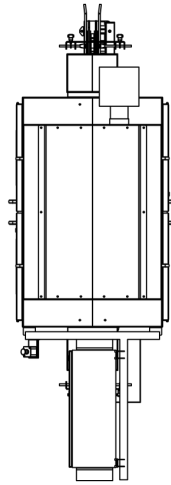
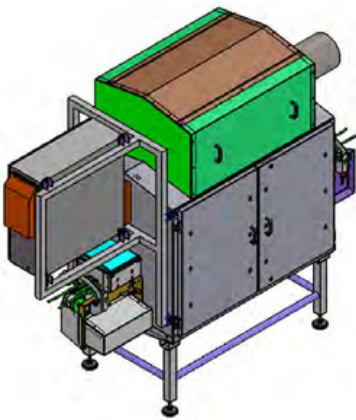
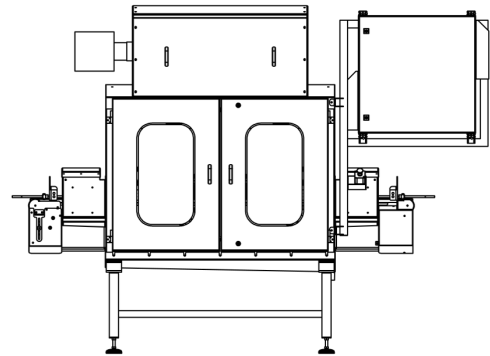
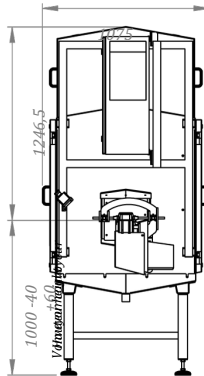
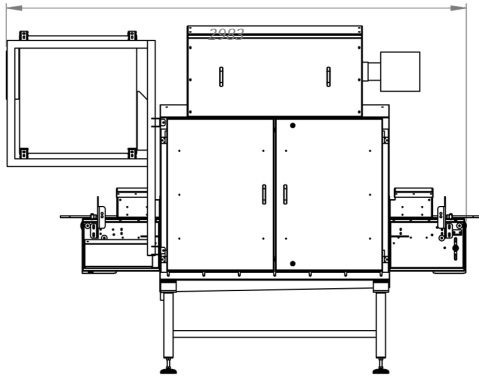

ADDRESS
CYAGO NV
Spinnerijstraat 103/03
B-8500 Kortrijk

CONTACT
Thibault Castel
Sales & Projects
thibault.castel@cyago.eu
www.cyago.eu